

# MOD-710

*Side seal plastic strapping machine*

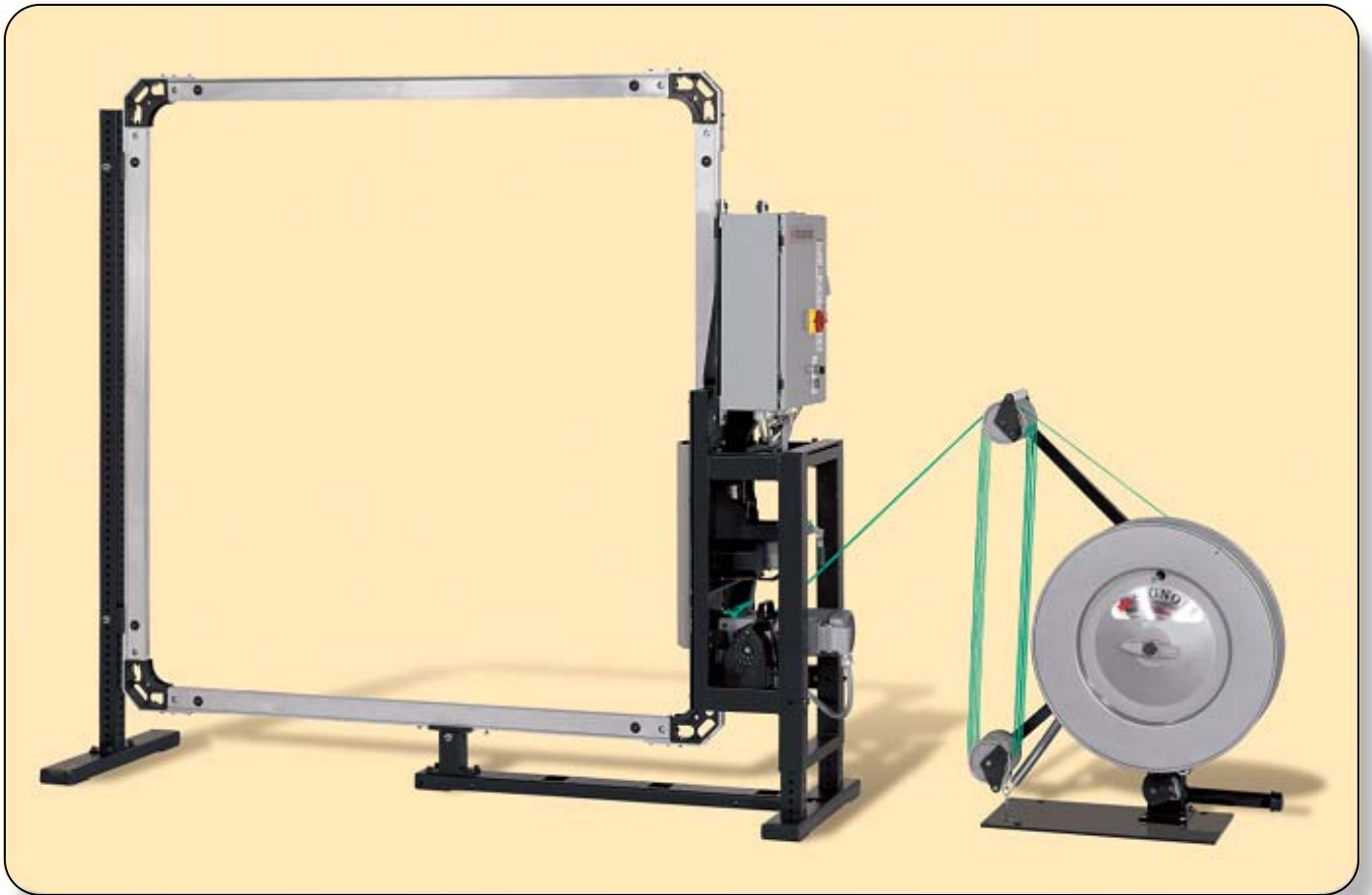

- ***Quick-change feed and seal modules***
- ***Smart-weld™ technology***
- ***High speed operation***

# MOD-710

## Side seal plastic strapping machine

The MOD-710's side seal plastic strapping machine combines Signode's quick-change modules with high speed, reliable operation to maximize productivity and reduce downtime. Simple to operate and easy to maintain, the MOD-710 with its large selection of chute sizes is ideal for a variety of packaging applications.

### Minimize downtime

The MOD-710's innovative modular design consists of separate feed and seal modules weighing less than 30 lbs. each. These lightweight, compact modules are easy to access and can be changed out quickly for routine maintenance. When switching to a spare module, downtime can be limited to a matter of minutes.

### Maximize reliability — Smart-weld™

The MOD-710 features the Smart-weld™ friction-weld seal joint. Smart-weld ensures that regardless of fluctuating voltage, each weld is created by the same amount of anvil resistance for maximum joint reliability every time.



### Options

- **Right-angle dispenser**  
Enables the dispenser to be placed parallel with conveyors.
- **Operatorless interlocks**  
Integrates the MOD-710 with conveyors and other equipment for fully automatic operation.
- **Auxiliary pendant**  
Allows the machine to be operated from either side.

### Specifications

#### Production rate:

Up to 1,500 straps per hour. Actual production will vary depending on package and chute size, operator dexterity and material handling equipment.

#### Strap feed and take-up speed:

11 feet (3.1m) per second

#### Strapping:

Signode Contrax® HD719, HD 723, HD729, and Tenax® 1616, 1716, 1718, 1822 plastic strapping.

#### Tension: 50 to 250 lbs (220 to 1110 N)

#### Electrical: 230/460 volt, 3 phase, 60 Hz

#### Shipping weight: 750 lbs (340kg)

#### Maximum package size:

The MOD-710 machine is available in a variety of chute sizes to accommodate the maximum package width and height combinations listed in the chart on the left.

		W - Maximum package width									
		18 in	24 in	30 in	36 in	48 in	60 in	72 in	84 in	96 in	108 in
H - Max. package height	24 in	18Wx24H	24x24	30x24	36x24	48x24	60x24	72x24	84x24	96x24	108x24
	30 in	18x30	24x30	30x30	36x30	48x30	60x30	72x30	84x30	96x30	108x30
	36 in	18x36	24x36	30x36	36x36	48x36	60x36	72x36	84x36	96x36	108x36
	48 in	18x48	24x48	30x48	36x48	48x48	60x48	72x48	84x48	96x48	
	60 in	18x60	24x60	30x60	36x60	48x60	60x60	72x60	84x60		
	72 in	18x72	24x72	30x72	36x72	48x72	60x72	72x72			
	84 in	18x84	24x84	30x84	36x84	48x84	60x84				
	96 in	18x96	24x96	30x96	36x96	48x96					
	108 in	18x108	24x108	30x108	36x108						

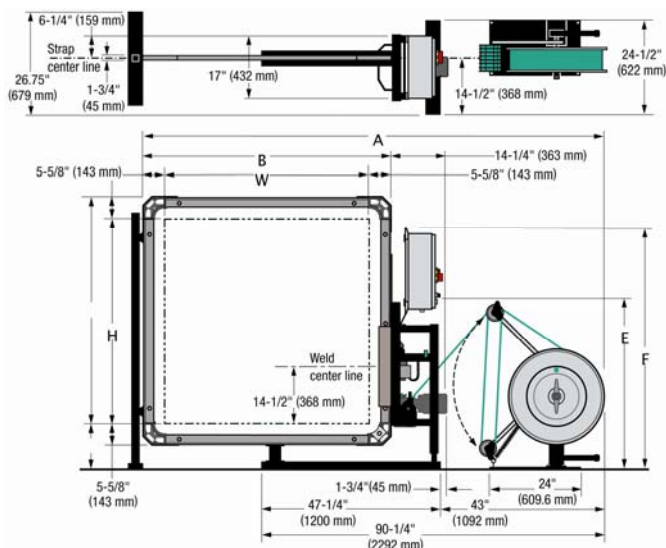

#### Variable machine dimensions:

- A Maximum package width from the chart, plus 66-3/4"
- B Maximum package width from the chart, plus 11-1/4"
- C Maximum package height from the chart, plus 5-5/8"
- D Conveyor height 8" to 29" in one-inch increments
- E Control height 41-1/2" to 62-1/2" in one-inch increments
- F Frame height 60" to 81" in one-inch increments
- H Maximum package height from chart

**SIGNODE®**

241 Gough Road  
Markham, ON L3R 5B3